

## M359-2 SERIES

UNINTERRUPTIBLE  
POWER SUPPLY



### PRODUCT HIGHLIGHTS

- FULL COMPLIANCE WITH MIL-STD-1399 (SECTION 300B)
- 3U RACKMOUNT
- 2.0KW/2.5KVA UPS
- 10-MINUTES HOLDUP TIME @ 1.5KW



# M359-2 2.0KW/2.5KVA UPS for Shipboard Application

Ruggedized, high performance On-Line UPS designed for Naval Shipboard and tough industrial applications.

## M359-2 Main Features:

- Full Compliance with MIL-STD-1399, Section 300B, Type I Power (115VAC/60Hz)
- Internal Input Isolation Transformer
- A front panel loaded, Plug-in Battery Pack
- Optional Extended Holdup-time (9 minutes at 1.9KW)
- Real sine-wave 115VAC/60Hz output, synthesized from a crystal oscillator
- Very low Input Current Harmonic content (MIL-STD-1399 compliant)
- Better than 98% Input Power Factor
- Very low input-to-chassis capacitance (MIL-STD-1399 compliant)
- Full galvanic isolation between Input, Chassis GND and Output
- 1,000V / 50 $\mu$ s spike capability (MIL-STD-1399-300B compliant)
- Complies with MIL-STD-461F
- Complies with MIL-S-901D (Grade A, Class I &2) and MIL-STD-167-1 (Type I)
- Remote Panel ON/OFF capability
- By-pass mode, via internal Power Conditioner, Isolation Transformer and Relays
- MS Power Connectors
- RS-232 or Ethernet SNMP v1, v2 or v3 Control and Monitor
- J-STD-001B and IPC-610A Class-3 Workmanship
- Polyurethane Conformal Coating on PWB's per MIL-I-46058C and IPC-CC-830

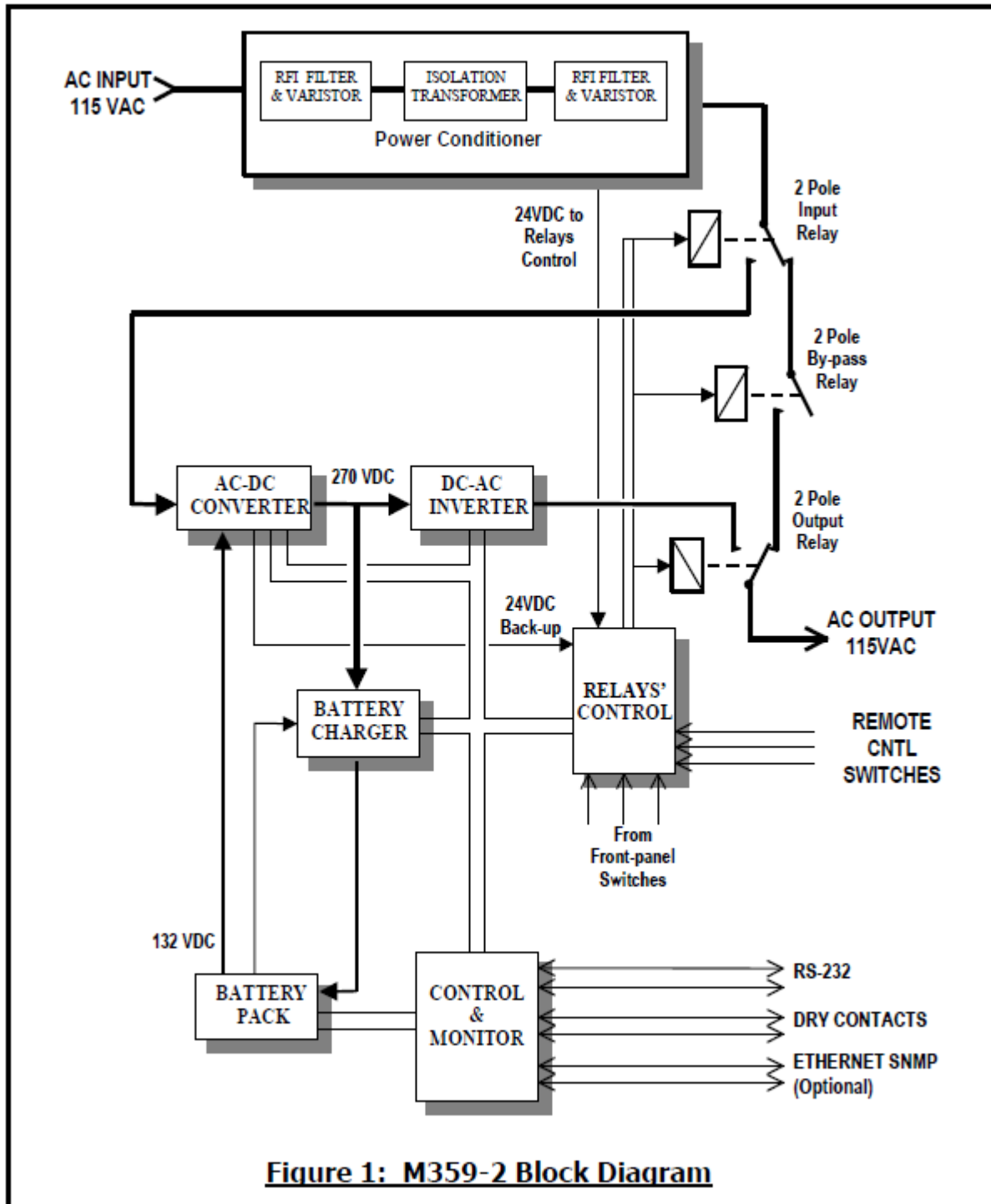

**Figure 1: M359-2 Block Diagram**

**Specification**

<b>INPUT</b>	<b>Voltage Range</b>	0 - 155VAC In Accordance with MIL-STD-1399, Section 300B.
	<b>Switchover Voltage</b>	Below 105VAC the M359 may switch to Battery power.
	<b>Frequency</b>	48-64 Hz
	<b>P.F &amp; Efficiency</b>	P.F. > 0.98 and Eff>85% (at 1,900W load)
	<b>Spikes</b>	Withstands the 1,000V Spike specified by MIL-STD-1399 (300B)
	<b>Isolation</b>	Input is isolated from output and chassis (> 10 M Ohm at 600VDC). Total capacitance between input and chassis is less than 0.02uf per line. Leakage current is less than 2ma. Compatible with both Ungrounded Shipboard Power and Grounded Neutral power.
	<b>Current Harmonic Distortion</b>	Less than 2.5% for harmonics between 2 fo to 32 fo and less than 100%/N for harmonics between N=32 and 20kHz. (I.A.W. MIL-STD-1399).
	<b>Inrush Current</b>	Limited Per MIL-STD-1399 (300B).
	<b>Power Interrupts</b>	No damage and no interrupt on Output voltage for all conditions of MIL-STD-1399 (300B)
<b>OUTPUT</b>	<b>Voltage &amp; Frequency</b>	115Vac $\pm$ 3%, grounded Neutral (Note 1). 60Hz $\pm$ 0.2% (digitally synthesized from a crystal oscillator)
	<b>Power Rating</b>	2.0KW (2.5KVA) Continues up to ambient temperature of +45°C. Derated linearly by 20W/°C to 1.8KW at +55°C (Note 2).
	<b>Waveform</b>	Sinusoidal , THD of 2% (linear load), 6% (non-linear)
	<b>Capability with Limited Input Current</b>	Delivers at least 1,900W when Input Current is limited to 25Amp
<b>BATTERY</b>	<b>Type</b>	Front Panel Loaded, Hot-swap Plug-in, encapsulated, sealed, maintenance-free, lead-acid, Battery Pack.
	<b>Capacity (minimum at 25°C)</b>	When using M359380-1 Battery: 1.9KW for 8 minutes and 1.5KW for 10 minutes. When using M359380-2 Battery: 1.9KW for 9 minutes and 1.5KW for 12 minutes.
	<b>Charger</b>	Low ripple, regulated float-charger, with current limiting and temperature compensation. Fully charges the battery within 6 hours (following full discharge at 1.9 kW).
	<b>Protection</b>	Protected from over-discharge and thermal runaway by internal protection circuit.
	<b>Monitor</b>	Charge level and internal impedance are monitored by the UPS micro-controller.
<b>EMC</b>	<b>MIL-STD-461F</b>	CE101, CE102, CS101, CS106, CS114, CS116 RE101, RE102, RS101 and RS103.
	<b>DC Magnetic Field</b>	1600A/m per DOD-STD-1399.

<p><b>ENVIRONMENT</b></p>	<p><i>Temperature</i></p> <p><i>Humidity</i></p> <p><i>Altitude</i></p> <p><i>Orientation</i></p> <p><i>Mechanical Shock</i></p> <p><i>Vibration</i></p>	<p>Non-operating: -40 to +72°C (Note 3) Operating: 0 to + 55°C (Note 2)</p> <p>Up to 95% RH per MIL-STD-810G, Method 507.5 Proc II..</p> <p>Operating: Up to 10,000 feet. Non-operating: (Air transport) 40,000 feet.</p> <p>May be installed at any orientation.</p> <p>Withstands the high-impact shipboard shock IAW MIL-S-901D, Grade A, Class I and II.</p> <p>Type I Deck Mounted vibration IAW MIL-STD-167-1. Random vibration IAW MIL-STD-810D, Cat. 9, Proc. I (test condition I-3.2.11, Fig. 514.3-34)</p>
<p><b>INDICATIONS &amp; CONTROLS</b></p>	<p><i>Visual Indications (Front panel)</i></p> <p><i>Test Mode</i></p> <p><i>Audible Alarm</i></p> <p><i>Power Switches</i></p> <p><i>Remote Control</i></p>	<p>10-segment tri-color Bar Graph for load level display. 10-segment Bar Graph for battery charge level display. "Output OK", "Output Fail" and "Standby" status lamps. "Input OK" and "Input Fail" status lamps. "On Batt " status lamp. "Batt Passed" and "Batt Failed" lamps for battery self-test. "Low Batt" warning lamp. "Overload Shutdown" status lamp. "Overtemp warning" and "Overtemp Shutdown" lamps.</p> <p>When test mode is invoked by pressing the push-button on the front panel, the UPS performs battery impedance testing without interrupting the output power (even if the battery fails) utilizing a proprietary time-sharing circuit. The test results are displayed on the panel indicators. End-to-End testing of the UPS is accomplished by cycling the INPUT UPS/BY-PASS switch on the front panel.</p> <p>The UPS will beep when it operates on battery power or during over-temperature condition. The alarm may be silenced by pressing the "Alarm Off" push-button on the front panel.</p> <p>The M359 has three double-pole power relays, one on the input, one on the output and a third relay that bypasses the UPS section. The front panel switches allow the user to control these three power relays.</p> <p>Connector J4 on the back panel, allows the controlling of the M359 by a remote 28Vdc/0.25A single pole, On/Off switch (Remote Power On/Off ) and a 28Vdc/0.25A, ON-ON, single pole switch (Remote UPS/By-Pass Select).</p>



**How to Order**

**Order P/N: M359-2 -0 -1 -0 -0**

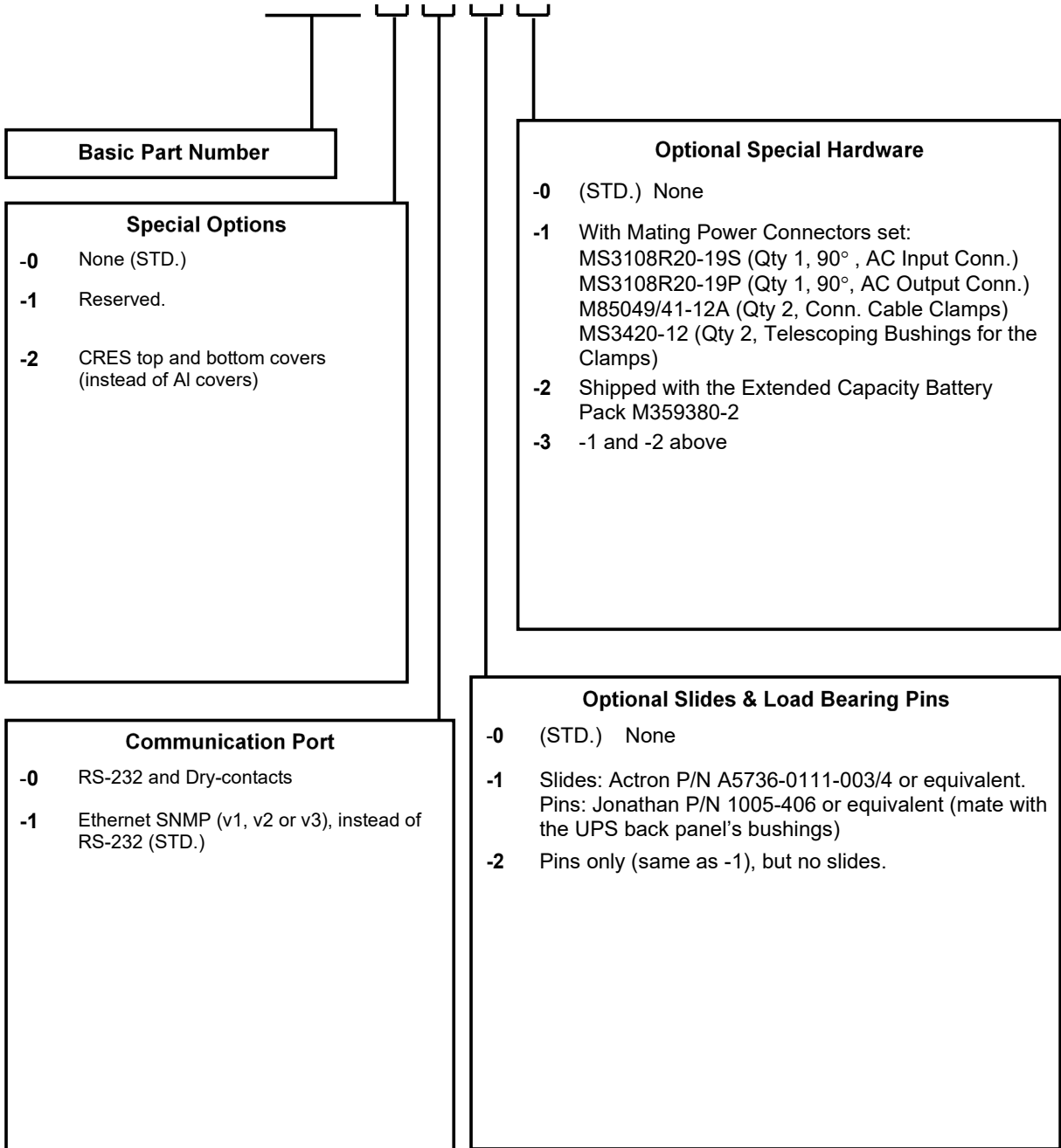

*Note: Specifications are subject to change without prior notice by the manufacturer*