

M4162 SERIES

DC/DC HOLDUP UNIT

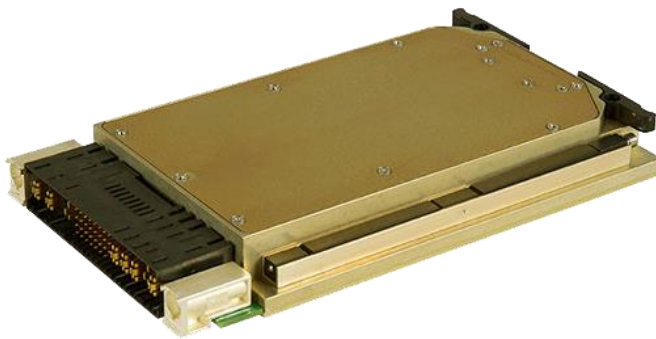

PRODUCT HIGHLIGHTS

- VITA 62 COMPLIANT
- 3U FORM FACTOR
- WIDE INPUT RANGE
- IPMI / 46.11 COMMUNICATION
- UP to 48J

M4162 Series– DC/DC HOLDUP UNIT

Electrical Specifications

DC Input

Up to 100V_{DC} Continuous work during MIL-STD-704 transients

Communication

IPMI / 46.11 protocol available for voltages

DC Output

VS1: Power
VS2: Power return
Normally: Input Follower
During Power loss:
Output is Up to 85V

Efficiency

Typical 98%

Isolation

Over 20 MΩ at test voltage: 200V between Input & output to case

EMC

Complies with MIL-STD-461F (5μH LISN): CE101, CE102, CS101

Environmental

Design to Meet MIL-STD-810G

Temperature

Operating: –55°C to +85°C at unit edge
Storage: –55°C to +125°C

Fungus

Does not support fungus growth, in accordance with the guidelines of MIL-STD-454, Requirement 4.

Vibration

Shock: Saw-tooth, 20g peak, 11mS.
Vibration: Figure 514.6E-1. General minimum integrity exposure. (1 hour per axis.)

Reliability

239,210 Hours, calculated IAW, MIL-HDBK-217F Notice 2 at +85 °C, GF (Max Holdup).

Note: **Environmental Stress Screening (ESS)** Including random vibration and thermal cycles is also available.

Please consult factory for details.

Altitude

Method 500.5, Procedure I & II Storage/Air Transport: 40 kft Operation/Air carriage: 70 kft

Humidity

Method 507.5, Up to 95% RH

Salt Fog:

Method 509.5

Shock

Method 516.6
40g, 11msec saw-tooth (all directions)

Normal Quiescent

Current:
Holdup Charging Current: 10A.
Normal Operation: 0.1A

Protections

Input

- **Inrush Current Limiter**
Peak value of 5 x I_{IN} for initial inrush currents lasting more than 50μSec.
Holdup Charging current up to 20A@500mSec.

- **Under Voltage**
Unit shuts down when input voltage drops below 11± 0.5V_{DC}.
Automatic restart when input voltage returns to 12V Line.

General

- **Over Temperature Protection**
Automatic shutdown at internal temperature of 95 ± 5°C.
Automatic recovery when temperature drops below 90 ±5°C.

Note: Thresholds and protections can be modified/removed (please consult factory)

M4162 Series– DC/DC HOLDUP UNIT

Normal Operation: During Normal Operation, the M4162 works as an Input follower. Small Voltage drop, of less than 1V is expected

Hold Up Operation: When Voltage at the input of the unit, drops below 18V, the Holdup will discharge it's internal capacitance into the DC Bus. During this time the M4162 output voltage will rise to 85V and will decrease as the capacitor bank energy will be discharging. Recharging of the capacitor bank will start before Input voltage goes back to steady state line.

The M4162 holdup charging time is less than 0.5Sec per Mil-STD-704, during charging time input current would be 10A-20A depends on input voltage.

Reducing Charging current and increasing charge time is optional.

Functions and Signals - According to VITA 62

Signal No.	Signal Name	Type	Description	Pin No'
1	Power Down	Output	Indicates that Holdup event has occurred. Open Drain. Normally Open, goes low during Holdup time.	D1
2	Power Ready	Output	Indicates to other modules that Holdup capacitor bank is Fully charged. Open Drain. Normally Open, goes low when Holdup energy under 90%.	A3
5	GA0, GA1	Input	Used for geographical addressing. GA1 is the most significant bit and GA0 is the least significant bit.	A5,B5
6	SCL, SDA	Bidirectional	I2C bus Clock and Data respectively. Through this bus the voltage and temperature readouts can be shared.	C5,D5

Simplified Block Diagram

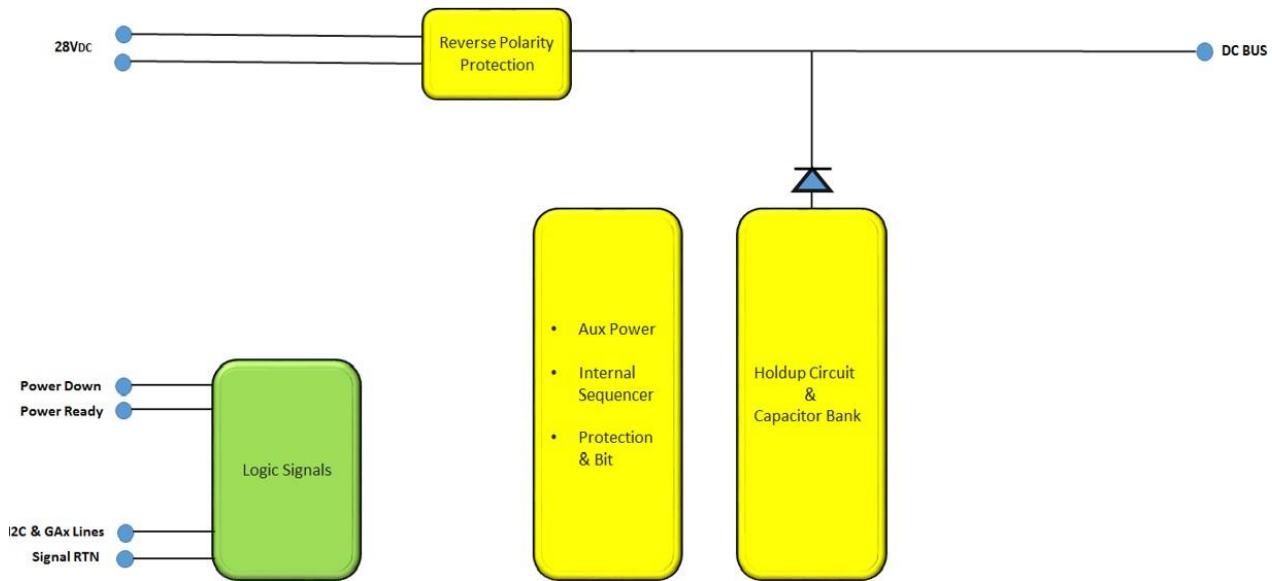

Typical Application

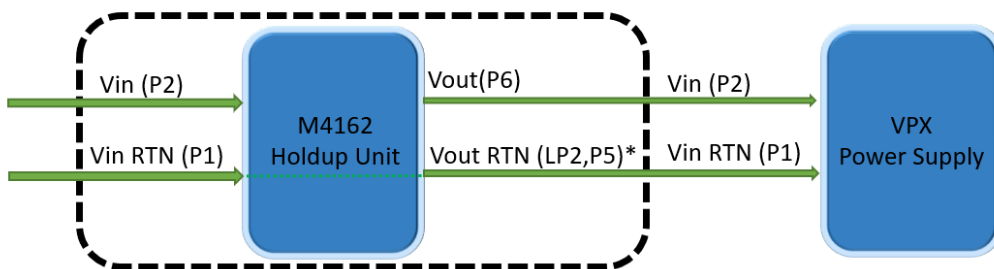

*

- Vin RTN & Vout RTN are internally shorted
- When Input Current exceed 20A, P5 should be added as Vout RTN line
- Since Hold-up event generate ground noise, it is important to keep Power Supply Input to Output grounds isolation
- All signals are floating and can be referred to Power Supply Signal ground

Electrical Interface

Vcc 3.3V
 Pull-up 2K
 Capacitance 330Pf

Communication Protocol

Slave Device Addressing

- 256 address spaces
- Baud rate: 200kHz maximum
- 7 Bit Protocol
- Support Slot Addressing per VITA 62

Slot Number	MSB							LSB
	A6	A5	A4	A3	A2/GA2*	A1/GA1*	A0/GA0*	R/W
Slot0	0	1	0	0	0	0	0	
Slot1	0	1	0	0	0	0	1	
Slot2	0	1	0	0	0	1	0	
Slot3	0	1	0	0	0	1	1	

* Slot location is determined by GAX per VITA 62.

Simplified IPMI Protocol (Optional, please refer to Cat Page)

Read Command – 21Hex, deliver 64Bytes of Data. (More commands are available by request) The communication starts when the master sends a start followed by the unit slave address, command, checksum, and a stop. A second start followed by the slave address and a read will be followed by a 64 Bytes response.

S	Slave Address	R/W	A	Command	A	Check sum	A	P
	A6:A0	0	0	21 Hex	0	DF Hex	0	

S	Slave Address	R/W	A	DATA	A	DATA	A	DATA	A	...	DATA	A	Check sum	N/A	P
	A6:A0	1	0	D7:D0	0	D7:D0	0	D7:D0	0		D7:D0	0	D7:D0	1	

Command – 21Hex read all 64 Bytes

S – Start

P – Stop

Master Transmit	Unit Transmit
-----------------	---------------

Memory Space

Response # Byte	Data Type	Meaning	Interpretation	Reading Range / Factor
0	U Integer, MSB First	Echo of Command		0x21
1	S Integer, MSB First	Reserved	0	0x00
2-3	S Integer, MSB First	Temperature (-)55C to 120C	Sign bit+15bit	(-)55°C to 125°C
4-5	U Integer, MSB First	Holdup Voltage	V = Data · m2	M2 = 0.00125
6-14	Character String (ASCII)	Part Number	M4162-xxx	Characters 9
15	U Integer, MSB First	Zero Checksum	Value required to make the sum of bytes 0 to 15 added to a multiple of 256	

46.11 Tier 2 (Optional, please refer to Cat Page)

Sensor ID	Name
0	FRU State Sensor
1	IPMB Link Sensor
2	FRU Health Sensor
3	FRU Voltage Sensor
4	FRU Temp Sensor
5	Test Results
6	Test Status
19	Analog Temp
---	Device Management
---	Device Locator

Pin Assignment

<i>Pin Number</i>	<i>Pin Name</i>
P1	-DC_IN
P2	+DC_IN
LP1	CHASSIS
P3	N.C.
P4	N.C.
P5	Bus_RTN
LP2	Bus_RTN
P6	Bus
A8	N.C.
B8	N.C.
C8	N.C.
D8	N.C.
A7	N.C.
B7	N.C.
C7	N.C.
D7	Sig_RTN
A6	SCL_B
B6	SDA_B
C6	N.C.
D6	N.C.
A5	GA0*
B5	GA1*
C5	SCL_A
D5	SDA_A
A4	N.C.
B4	N.C.
C4	N.C.
D4	N.C.
A3	Power_Ready
B3	N.C.
C3	N.C.
D3	N.C.
A2	N.C.
B2	N.C.
C2	N.C.
D2	N.C.
A1	N.C.
B1	N.C.
C1	N.C.
D1	Power_Down

M4162 Series– DC/DC HOLDUP UNIT

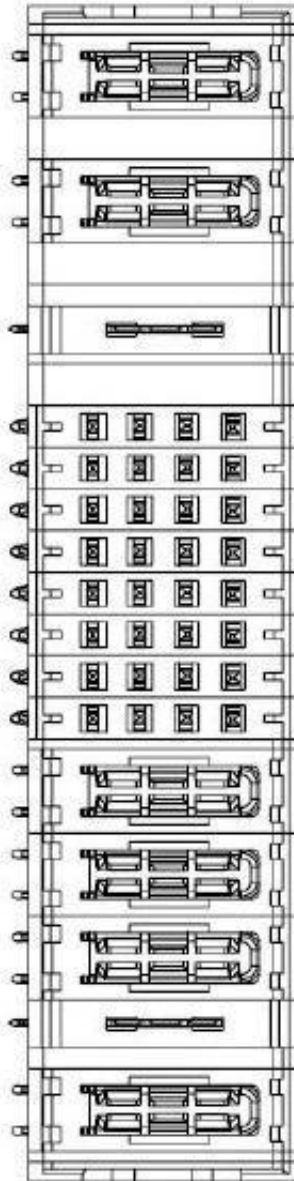

2ACP+1LP+32S+3HDP+1LP+1HDP

PART NUMBER	ROWS	POWER						SIGNAL								POWER					
		P1	P2	LP1	1	2	3	4	5	6	7	8	P3	P4	P5	LP2	P6				
6450849-7	D				Z5	Z5	Z5	Z5	Z5	Z5	Z5	Z5	Z5	Z5	Z5						
	C			LT	Y5	Y5	Y5	Y5	Y5	Y5	Y5	Y5	Y5	Y5	Y5	TT	TT	TT			
	B	TT	TT		R5	R5	R5	R5	R5	R5	R5	R5	R5	R5	TT	TT	TT				
	A				05	05	05	05	05	05	05	05	05	05	01			TT			

M4162 Series– DC/DC HOLDUP UNIT

Outline Drawing

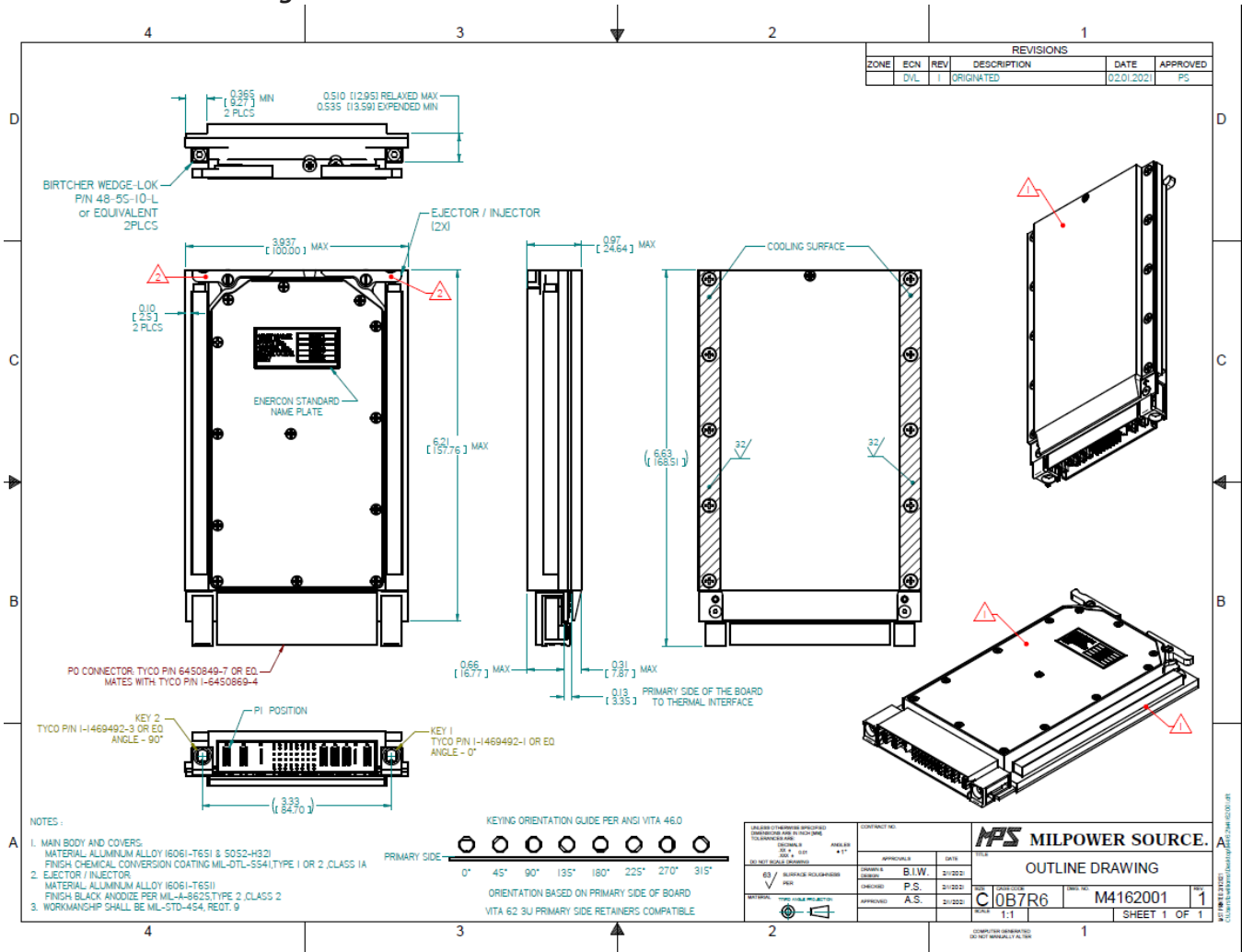

Notes:

- Dimensions are in inches [mm]
- Tolerance is:
.XX ± 0.02 IN
.XXX ± 0.008 IN
- Weight: 1 Kg
- 3D model available

Note: Specifications are subject to change without prior notice by the manufacturer.

Cham, Switzerland | www.enercon-europe.com | sales@enercon-europe.com

Netanya, Israel | www.enercon.co.il | sales@enercon.co.il

Gurgaon, India | www.mpsindia.in | sales@mpsindia.in